

Walk-through Metal Detector

User's Manual

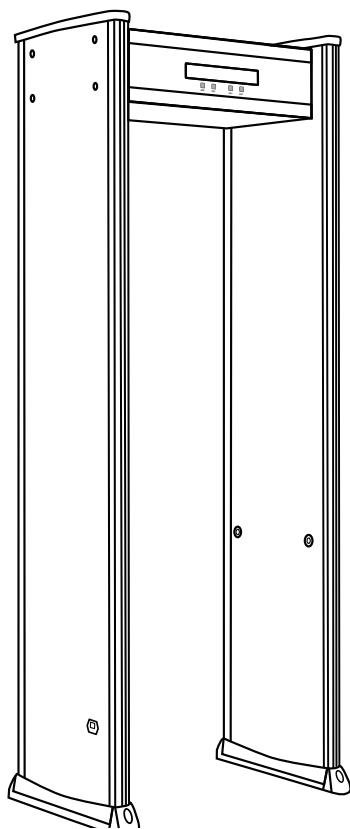

———— V2.0 ————

[Table of Contents]

Precautions-----	1
Product introduction-----	2
Suitable places-----	3
Performance and characteristics-----	3
Installation conditions-----	4
Installation specification-----	5
Display specification-----	6
Operating specification-----	7
Detection adjustment-----	13
Common problem handling-----	14
Standard compliance-----	15
Technical parameter-----	16
Inspection report-----	17
Packing list -----	17
“Green channel” after-sales service system-----	18
Maintenance document-----	18
Disclaimer-----	18

Note: Please read this Manual carefully before operation.

[Precautions]



- I. **The Walk-through Metal Detector (WTMD) is only available for indoor use. Outdoor installation is not allowed, otherwise rainproof / sunproof facilities such as awnings shall be used. The Walk-through Metal Detector (WTMD) shall not be installed at high temperature and moisture places.**
- II. **The Walk-through Metal Detector (WTMD) shall be installed at flat and vibration-free places for fear of wagging and causing false alarms.**
- III. **The Walk-through Metal Detector (WTMD) can only reach the best inspection effect after the 1 min self-inspection.**
- IV. **Persons shall be inspected one by one according to the stringent stand-by or alarm time settings (more than 1s). Crowding around the Walk-through Metal Detector (WTMD) is not allowed for fear of infrared sensation interference.**
- V. **Please DO NOT knock on or hit the WTMD during inspection for fear of false alarms or even damage.**
- VI. **Dirt or dust shall be removed carefully with a cloth dipped with a little water or alcohol. Direct rinse with water or other chemical solvents is not allowed.**
- VII. **The equipment shall not be opened without permission for fear of high voltage and other man-made accidents.**
- VIII. **The Walk-through Metal Detector (WTMD) has been provided with a guarantee. The maintenance is free within the guarantee period as specified in the guarantee.**

[Product introduction]

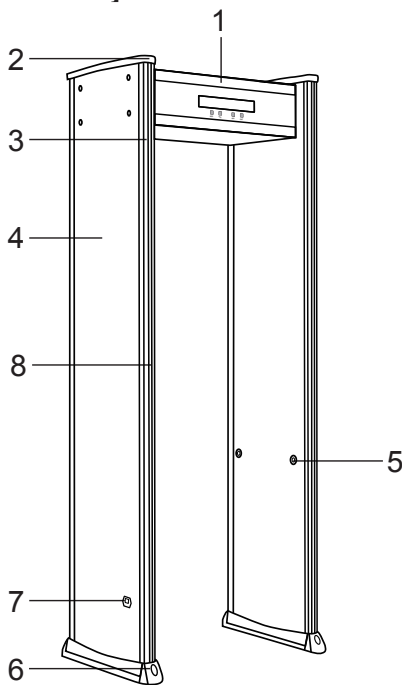

1. Main case 2. Top cover 3. Aluminum strip and light cover 4. Door plate
5. Infrared sensor 6. Stabilizer base 7. Power supply socket 8. Led light bar



Stabilizer base



Power supply socket



Remote controller + key

Walk-through Metal Detector is a kind of fixed installed detection equipment. It is also called metal detection door and can be called as security door for short. It is mainly used to detect metal objects hidden on human body. When the personnel to be check are walking through the security door, if the metal brought by the personnel exceeds the preset parameter value, the security door will send alarm sound immediately and display alarm location so that the security personnel can timely find out prohibited metal articles.

As one of the product of highest technical content, our product feature in quick response, accurate detection, high sensitivity and strong anti-interference, so it can meet the needs by users from all industries.

[Suitable places]

- I. Suitable for law enforcement agencies:** Including public security departments, procuratorates, courts, prisons, reformatories and penitentiaries etc. requiring forbidden metallic article inspection.
- II. Suitable for public places:** Including public places such as gymnasiums /stadiums, recreation places, airports, customs authorities, exhibition halls and museums etc. requiring entrance safety inspection.
- III. Suitable for manufacturing enterprises:** Including electronic product, hardware, coinage and jewelry manufacturing enterprises etc. requiring safety inspection for fear of loss of valuables.
(Hand metal detectors are suitable for all the above mentioned places and therefore are necessary auxiliary inspection equipment for inspectors).

[Performance and characteristics]

- I. Accurate localization:** Six overlapped netlike detection locations, double side emission, double side reception, accurate localization of detected articles and visual display of objects.
- II. Multi-location alarming:** More than one metal position can be localized at the same time.
- III. Microprogramming technology:** The electromagnetic wave used for scanning can be generated by the control circuit of microcomputer and the scanning rate can be controlled accurately. The program can be set via the control panel according to the requirement in order to ensure flexible, reliable and stable sensitivity setting.
- IV. Compound circuit design:** The infrared scattering device with quick sensing and automatic computer identification functions can help to reduce false alarms and alarm failures. The number alarms and passed persons can be recorded automatically.
- V. Digital pulse technology:** A digital signal processing and filtering system with perfect EMI resistance is provided.
- VI. Adjustable sensitivity:** Each detection zone has been provided with 1000 sensitivity levels (0 ~ 999), and therefore the location can be adjusted to an available sensitivity according to the detection requirement (the higher the set value is, the higher the sensitivity will be). The integral sensitivity can be realized through adjusting the six locations at the same time.
- VII. Password setting:** Change of parameters regarding program and sensitivity etc. is only allowed after the password is entered correctly. The password consists of six figures set freely by users (**Note:** The passwords with regard to setting items of the system are unchangeable).
- VIII. Serial port communication:** Data communication interfaces are reserved for online operation.
- IX. Modular design:** The adopted modular design realizes easy installation and troubleshooting.
- X. High impact resistance design / manufacturing:** High impact / bump resistance when no one passes through. The stand-by or normal operation modes can be kept in good conditions regardless of any external factor.
- XI. Magnetic field emission technology:** The product can meet the popular international safety standard and the weak magnetic field technology has been adopted and therefore does no harm to pacemaker users, pregnant women, floppy disks, films and videotapes etc.

[Installation conditions]

I. Stationary metal articles

The Walk-through Metal Detector (WTMD) shall be at least 50cm away from stationary or fixed big metal articles, otherwise false alarms will be caused.

II. Movable metal articles

Movable big metal articles shall be 1 ~ 2m away from the Walk-through Metal Detector (WTMD) for fear of false alarms, especially when the Walk-through Metal Detector (WTMD) is to be installed at factory gates or bottom floors of buildings, the affection of rolling gates, iron security doors and grid doors shall be considered. The bigger the area of different metal articles is, the farther the distance between the Walk-through Metal Detector (WTMD) and them shall become.

III. Floor vibration

The floor shall be flat and firm in order to prevent the installed Walk-through Metal Detector (WTMD) from wagging due to walking people or moving metal articles or causing unnecessary false alarms.

IV. Electromagnetic radiation and interference

Since the double side emission / reception technology is adopted for the Walk-through Metal Detector (WTMD), any electromagnetic interference and radiation source shall be kept away from both sides. The suggested distance is 1 ~ 2m.

Possible sources with electromagnetic interference and radiation are:

electrical equipment control box, RF equipment, computer and the peripheral equipment, video monitor, high-power motor, high-power transformer, AC power line, thyristor control circuit (switching mode high power supply , inverter welder), engine, machine with motor and daylight lamp with demode electronic ballast.

V. Notes when two or more Walk-through Metal Detector (WTMD)s of different series are used

When two or more Walk-through Metal Detector (WTMD)s are used together, interference will be caused, which differs with the distance among WTMD and the selected working frequency; When installing two or more Walk-through Metal Detector(WTMD), the automatic frequency setting function shall be enabled and the machines, started in order. The frequency settings shall be different from each other, and the distance between Walk-through Metal Detector (WTMD)s shall be not less than 50cm.

VI. Installation at places with wind is not allowed

The WTMD will waggle slightly in case of wind, causing false alarm during normal operation.

[Installation specification]

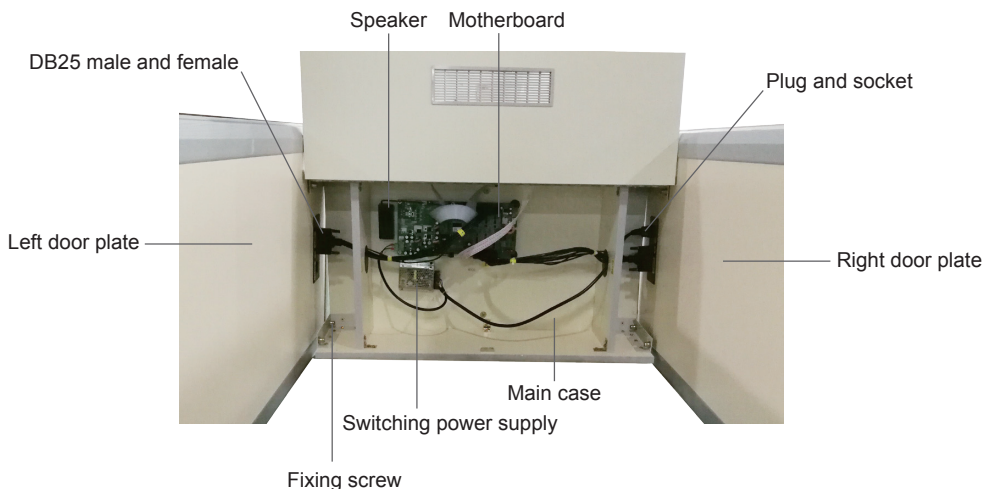

I. Installation instruction

1. Remove the packages of the main case and door plates.
2. Face the panel of the main case up, put the right and left door plates (as shown in the figure) at the specified places and put the fitting box aside.
3. Put the right / left door plates and main case close to each other erectly and fix them together with 8 fixing screws of the fitting box with an allen wrench.
4. Insert the DB25 plugs of the main case into the corresponding DB25 sockets of the right / left door plates separately.
5. Insert the 3-pin plug of the external power cable of the fitting box into the socket being at the bottom of the outside of the door plate (Note: The power supply is only connected when the socket used for the external power cable and that used for the main case cable are set at the same door plate).

II. Direction for use

1. After the Walk-through Metal Detector (WTMD) is installed, keep pressing “A” of the remote controller of the fitting box until the machine is started and the panel lights up;
2. The started Walk-through Metal Detector (WTMD) will perform self-inspection and the item displayed on the panel will change and twinkle. When the displayed item stops twinkling, both the number of passed persons and alarms will be “0”, meaning that the startup operation finishes.

Note: The Walk-through Metal Detector (WTMD) is available for customized settings based on different conditions and requirements, see the “Operating specification” for the detailed setting.

[Display specification]

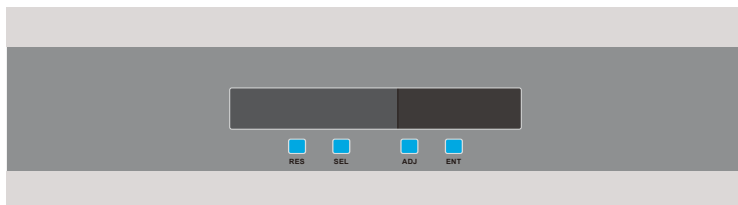

I. Panel specification

A blue backlight LCD screen is set at the left side of the panel. When the machine is used under the stand-by mode, the number of passed persons, alarms, time and date can be shown; A light plate comprising of stand-by, alarm and intensity indicator lights is set at the right side.

II. LED light specification

1. The first vertical zone comprises of green stand-by indicator lights. The second vertical zone comprises of alarming indicator lights, other zone comprises of red intensity indicator lights.
2. After the machine is started, the green stand-by indicator light will be On when no any metal article passes through; the stand-by indicator light will be Off when any metal article passes through and the red alarm indicator light will be On with warning tone. The bigger the metal size is, the more the alarming intensity indicator lights will appear.

III. LED light bar of door plate

1. The door plate comprises of 6 zones (zone 1 - 6) from the bottom to the top, which can show the location of detected metals accurately.
2. The door plate edge indicator is led light bar. When any metal article passes through, the led light bar will be On. The bright area shows the location of the metal article. When the metal near the left door, the left side lights on, and the right door lights on when near the right door, so the door is divided into 12 zones.

[Operating specification]

I. Remote controller specification:

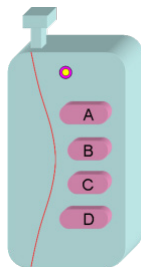

A - “Power ”

B - “Select”

C - “Adjust”

D - “Enter”

1. The “A” (power) has two functions for the actual operation:

- (1) On / Off: The system can be started by pressing it for more than 1s and stopped by pressing it for more than 3s.
- (2) Reset: The system can be reset by pressing it for 0.5 ~ 3s at any interface.

2. The “B” (Select) has one functions for the actual operation:

Selection: Menus or digits can be selected, i.e. the key can be used together with “C” for selection.

3. The “C” (Adjust) has two functions for the actual operation:

- (1) Number modification: Numbers can be modified in the password setting menu;
- (2) Selection: Menus can be selected, i.e. the key can be used together with “B” for selection.

4. The “D” (Enter) has three functions for the actual operation:

- (1) Confirmation: When a menu is selected and confirmed, the password input interface of the secondary interface can be shown if the key of the main interface is pressed after startup.
- (2) Setting saving: The modified menu or parameter can be saved.
- (3) Number modification: When the sensitivity and alarm are set, the numbers can be modified.

II. Basic operation

1. **Startup:** The system under the shutdown mode can be started by pressing “A” for more than 1s. The system performs the signal self-inspection during the startup. If the inspection meets the requirement, a “√” will be shown, if the inspection fails to meet the requirement, an “×” will be shown. After the inspection finishes and the frequency setting is OK, the main interface will be shown as Fig. 1.

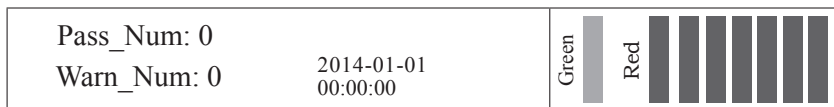

Fig. 1

2. **Shutdown:** The system under the operating mode can be shut down after “A” has been pressed for more than 3s and the ring has been triggered.

3. **Reset:** Under the operating mode, the system can be reset by pressing “A” at any interface for 0.5 ~ 3s, and at this time the interface will go back to the initial one as shown when the machine is started and the number of passed persons and alarms will be reset.
4. **Check of program version number:** As shown in Fig. 2, the program version number will be shown on the screen when “B” is pressed twice continuously at the main interface. The main interface will be recovered when “B” is pressed again.



Fig. 2

III. Functional parameter setting

The parameters of the Walk-through Metal Detector (WTMD) can be set according to the requirement. The parameter setting is password protected for fear of unauthorized modification. Important parameters are two-password protect.

Press “D” under the main interface to enter the password input interface, see Fig. 3.



Fig. 3

1. Password specification

- (1) The digits can be switched by pressing “B” at this interface. The selected digit can be modified by pressing “C”. The input password can be confirmed by pressing “D”; The main interface will be shown again if no any operation is performed in the password input interface after 10s. The user will be required to input the password again in case of incorrect one after “D” is pressed.
- (2) The initial password for parameter setting is “000000”, which can be modified after the user enters the parameter setting interface. A universal password of “612184” has been reserved in the system, which can be used when the customized password is forgotten.
- (3) The system setting interface is used for important parameter setting, which is only enabled after the password of “654321” is input. This password is unchangeable.

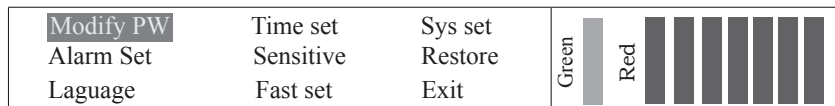

Fig. 4

2. Password modification

- (1) The password modification interface can be shown by selecting “Modify PW” and pressing “D” in the parameter setting interface, see Fig. 5.



Fig. 5

- (2) The digits can be selected by pressing “B”. The selected digit can be modified by pressing “C”. The password setting can be confirmed by pressing “D”. The modification is only effective after the same password is input twice.

3. Alarm setting

- (1) Select “Alarm set” in the parameter setting interface to enter the alarm setting interface, see Fig. 6.

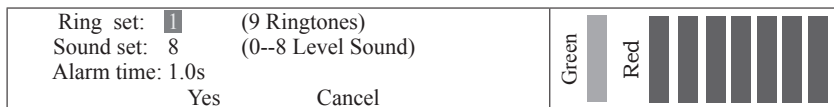

Fig. 6

- (2) The alarm setting comprises of “Ring set” , “Sound set” and “Alarm time”. Press “B” key for up selection , press “G” key for down selection , press “D” to modify the selected item, which the alarm time is adjusted by 0.5s/step. After modification, select “Yes” key and press “D” key will save the changes, select “Cancel” and press “D” key will exit the interface directly, so the modified parameters will not be saved.

4. Language selection

Select “Language” in the parameter setting interface to enter the language selection interface, see Fig. 7. The languages can be switched by pressing “B” or “C”. After the modified item is saved by pressing “D”, the interface will go back to the last menu.



Fig. 7

5. Time setting

- (1) Select “Time set” in the parameter setting interface to enter the Time setting interface, see Fig. 8.

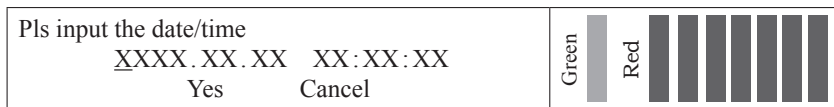

Fig. 8

- (2) The date and time digits selection can be performed by pressing “B” or “C” in the time setting interface. The selected item can be modified by pressing “D”. After the modified item is saved by selecting “Yes” and pressing “D”, the interface will go back to the last menu. The modified parameter will not be saved by selecting “Cancel” and pressing “D”.

6. Sensitivity setting

Select “Sensitive” in the parameter setting interface to enter the sensitivity setting interface, see Fig. 9. The location can be selected by pressing “B”. The sensitivity digit of a location can be selected by pressing “C”. The sensitivity value can be modified by pressing “D”.

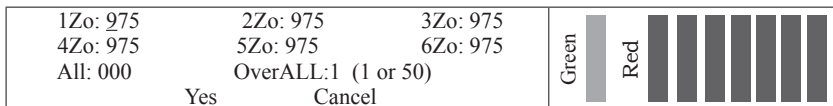

Fig. 9

- (1) The sensitivity from Location 1 to 6 can be set separately or set as the same one for the sake of convenience. The sensitivity from Location 1 to 6 can be set as the same one by specifying “All” as a non-zero value, e.g. When the “All” is set as 150, then the sensitivity from Location 1 to 6 can be Level 150 after the setting is saved.
- (2) “Integral” covers all locations, where “Once” or “50 times” can be selected. If “Once” is selected, the sensitivity will not change; If “50 times” is selected, the sensitivity will be reduced by 50 times.
- (3) The adjusted sensitivity shall be confirmed and saved by selecting “Yes” and pressing “D”, the interface will go back to the last menu. The set parameter will not be saved by selecting “Cancel”.

Note: The adjustable levels with regard to sensitivity are restricted within Level 0 ~ 999. The higher the value is, the higher the sensitivity will become; The higher the multiple of is, the lower the sensitivity will become.

7. Fast set

In the parameter settings interface, select the "Fast set" item to confirm, enter the fast setting interface, see Fig. 10.

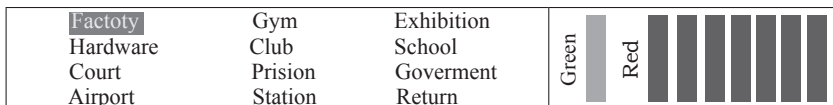

Fig. 10

- (1) There are 11 special places selectable in the fast setting item. The corresponding parameters can be set in advance for reference according to the corresponding environment, to set the required sensitivity quickly.
- (2) In fast setting, select the desired place, press "D" key to confirm, the interface directly return to the previous menu interface, if you select "return to the higher level" to confirm, setting parameters will not be modified.

8. Factory setting restoring

Select “Restore” in the parameter setting interface to enter the sensitivity setting interface, see Fig. 11. Press “B” or “C” to select “Yes” or “No”. If “Yes” is selected, the system, by pressing “ENT”, will restore the factory settings and go back to the interface as shown in Fig. 1. If “No” is selected, the system, by pressing “ENT”, will not restore the factory settings but go back to the interface as shown in Fig. 4.

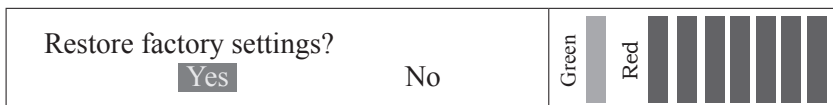

Fig. 11

IV. System parameter setting

The system setting interface is used for important parameter setting, which is only enabled after the password of “654321” is input. See Fig. 12.

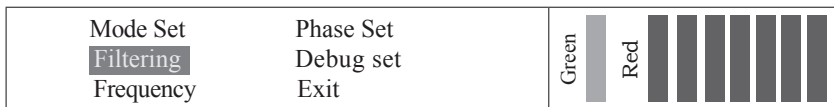

Fig. 12

1. Work mode

12 zones can not be changed.

2. Filter mode setting

In the system settings interface, select "Filtering" to confirm, enter the filter settings interface, see Fig. 13.



Fig. 13

"BPF" : filter high frequency and low frequency interference.

"HPF" : filter out the interference of low-frequency drift.

"LPF" : filter out high frequency interference.

"No filter" : the original data does not do filtering.

Note: The filter mode can filter out interference, reduce the false alarm rate, but after filtering the signal will have a certain delay, the alarm will be delayed as well. Bandpass filter is the best, but the delay is also the longest; this function is based on the surrounding environment, if less interference, no need to filter; more than (more than 4) doors work at the same time, there will be some interference between each other , May cause false positives, can be set to filter mode.

3. Frequency setting

Select the “Frequency” in the system setting interface to enter the frequency setting interface, see Fig. 14.

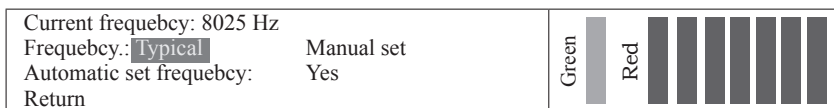

Fig. 14

“Current frequency”: The frequency used for current operation of the system.

“Frequency”: The working frequency of the system can be set through “Typical” and “Manual set”

(1) Typical frequency: see Fig. 15.

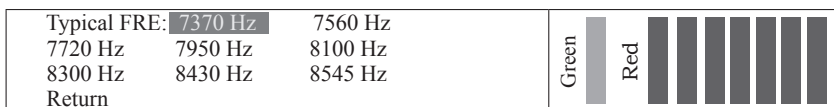

Fig. 15

“**Typical FRE**” refers to those frequency values selected according to tests, which can help to realize easy frequency setting. The frequency selected for the setting will be saved in the system automatically by pressing “D”.

(2) Manual setting: see Fig. 16.

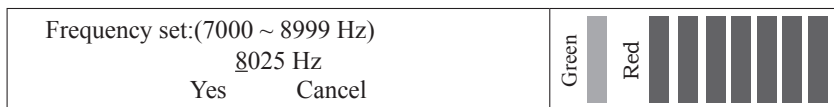

Fig 16

The easier manual frequency setting, taking 1Hz as one stepping, is allowed within 7000 ~ 8999Hz.

Note: When the frequency is about 8000Hz, the system performs the best. Generally, the frequency shall be kept within 7350 ~ 8700Hz.

4. Automatic frequency setting after startup

“**Automatic set frequency**”: When “Yes” is selected, the system will check the frequencies of ambient machines automatically in order to set different frequency. When more than one WTMDs are used at the same time, the frequency of each one can be staggered automatically for fear of repeat and high mutual interference during the operation.

Note: When more than one WTMDs are to be used at the same time, just select “Yes” and then start them in order. The frequency setting of one machine must be finished before the next one is started.

V. Other functional settings

The “Phase set” and Debut set” are used for research, development and commissioning and therefore unauthorized modification is not allowed.

[Detection adjustment]

I. The Walk-through Metal Detector (WTMD) can only meet the highest performance under stable conditions. Steps for checking the Walk-through Metal Detector (WTMD) for being used under stable conditions:

1. Check the installation position of the Walk-through Metal Detector (WTMD) for meeting the requirement of "installation condition".
2. The Walk-through Metal Detector (WTMD) shall not waggle after startup.
3. The alarm is not triggered when the tester without metal articles passes through the WTMD; The alarm is triggered when the tester with metal articles (e.g. keys) passes through the WTMD.
4. The Walk-through Metal Detector (WTMD) can be considered as being used under stable conditions when meeting the above items.

II. In order to prevent personal belongings such as rings, keys, buckles, leather shoes with metal parts etc. from affecting those metal articles required to be detected, the following adjustment steps shall be conducted:

1. Increase the sensitivity, the alarm shall be triggered when passing the WTMD with those metal article exceptions;
2. Decrease the sensitivity (within an appropriate range), pass the Walk-through Metal Detector (WTMD) again with those metal article exceptions until the sensitivity is just decreased to the level causing no alarms.

Note: If the zone that require small article exceptions is certain, just set its sensitivity independently; If the zone that require small article exceptions is not certain, all zones can be set at the same time.

III. Inspection rules of the Walk-through Metal Detector (WTMD)

1. A warning line being 50 cm away from the front / rear of the Walk-through Metal Detector (WTMD) shall be drawn in order to make the persons to be inspected pass one by one.
2. Before the persons to be inspected passes the WTMD, those carried metal articles such as keys, cell phone, iron trade mark articles, cigarette and coins etc. shall be put at a specified position. The above mentioned articles can be taken back after the inspection.
3. The persons to be inspected shall walk through the WTMD, normally one by one. Crowding, intended rush or ambling as well as impacting the door plate are not allowed.
4. For the WTMD inspection, the person shall be inspected after the last one passes the warning line without triggering the alarm. If an alarm is triggered, the person shall be inspected after the alarm tone stops.
5. A person passing through the Walk-through Metal Detector (WTMD) triggers the alarm means that metal articles are carried. The metal article location can be found according to indication of the LED light bar (The bought "Hand metal detector" produced by our company can used together).
6. The person to be inspected shall not wear jewelries or clothes, caps and footwear with metallics for fear of affecting normal inspection of metal articles.

[Common problem handling]

I. Infrared sensor counting failure

1. Check both ends of the sensor leads in the main case for being correctly connected.
2. If both ends of the sensor leads are connected correctly, check the emission voltage of the infrared modules for being in good condition. Resistor R5 and R286 are emission ends. The voltage R5 / R286 and U2 / U36 connecting ends is approx. 2.5V. D2 and D13 are reception ends. When the infrared is not blocked, the voltage of the 3rd pin of D2 and D13 is close to 0V. When the infrared is blocked, the voltage of the 3rd is higher than 3V. If the voltage of the infrared module emission and reception ends is normal, check IC U21 of the main controller.
3. If one or a pair of the infrared module emission and reception ends does not work, the infrared tube shall be checked for being burnt or bad connection or the system for bad wiring.

II. False alarm

1. If frequent false alarm appear, check the installation conditions of the Walk-through Metal Detector (WTMD) for meeting the “Installation conditions”.
2. If the installation meets the “Installation conditions”, check the right / left door plates for being installed backwards.
3. If the door plates are installed correctly, try to decrease the sensitivity of all zones and check the false alarm for being handled.
4. If this problem is still not handled through decreasing sensitivity, check the voltage for being normal. Normal working voltage shall be 110 ~ 240V. False alarms might be caused if the voltage is lower than 110V (handling method: Try to buy an adjustable booster or a back-up UPS power supply).
5. If the working voltage is kept within the normal range, check the oscillation frequency for being normal. Stagger the interference by changing the frequency and the perform further tests.

III.Startup failure

1. If a startup failure appears, check the voltage for being kept within a normal range. If the supply voltage is lower than 90V, the machine will not be started up (Try to buy an adjustable booster).
2. If the voltage is kept within a normal range, check the input end of the switching supply. If no voltage is found, check the fuse for being burnt out. If the voltage is normal, check the output end voltage of the switching supply for being 12V. If the voltage is 12V, check the voltage values of the motherboard and MCU for being 5V and 3.6V respectively.

IV.Alarm failure

1. If an alarm failure occurs, check the alarming mode firstly. If the alarming mode is “With infrared”, the alarm is only available with infrared counting; If the alarming mode is “Without infrared”, check the oscillation signal for normal output.
2. If the alarm failure still exists though the oscillation signal is normal, the DC power values of the motherboard shall be checked for being +8V, -8V and +12V respectively with a multimeter.
3. If the DC power values of the motherboard are +8V, -8V and +12V, the reference voltage shall be checked for being 3.6V with a multimeter.
4. If the reference voltage is 3.6V, the 3rd-pin DC voltage of Q21 and Q25 of the motherboard shall be checked for being close to -8V and 0V respectively with a multimeter.

V. Wiring diagram of circuit board:

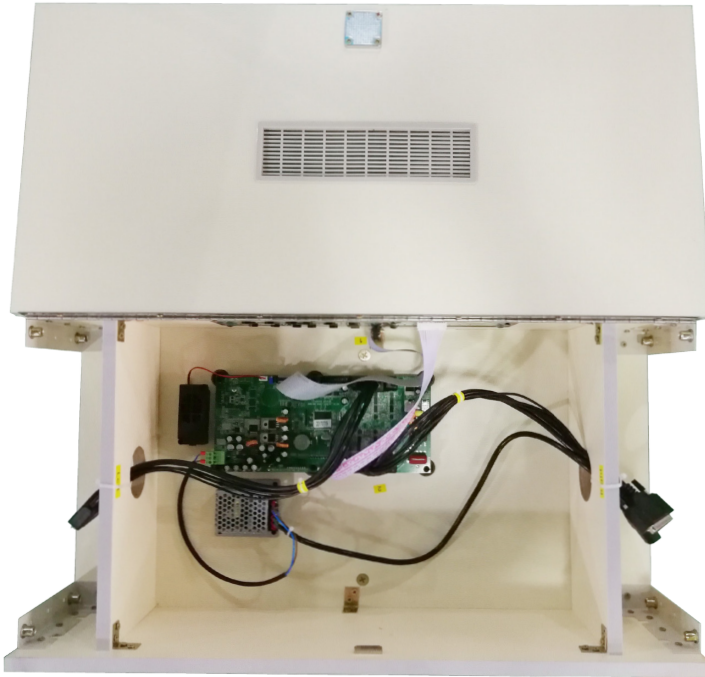

Motherboard +Switch power supply+ LCD + Lamp panel+ Speaker

[Standard compliance]

This product meets the Technical Code for GB15210-2003 Walk-through Metal Detector (WTMD).

[Technical parameter]

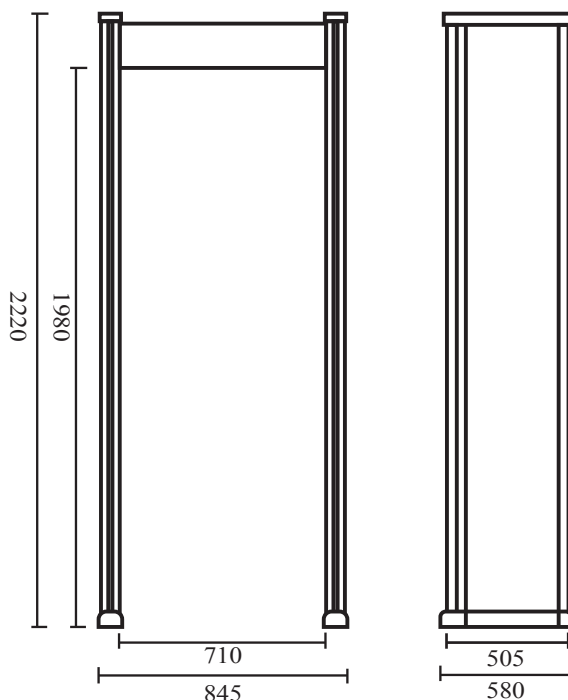

OPS: AC 100V ~ 240V 50 / 60Hz

Actual power consumption: < 12W

Signal freq.: 7000Hz ~ 8999Hz, adjustable

Operating ambient temperature: -20 ~ 45°C

Operating ambient humidity: ≤ 98%

Weight of entire packaged product: Approx: 70kg

Overall dimension: H 2220MM x W 845MM x D 580MM

Passage size: H 1980MM x W 710MM x D 505MM

Package size: Door plate: L 2260MM x W 630MM x H 170MM

Main case: L 750MM x W 240MM x H 430MM

[Inspection report]

Name	Walk-through Metal Detector	Model		Serial No.	
Insp. date		Insp. equipment		Aging time	
Functional inspection item:					
1. Infrared		4. Alarm			
2. Power supply		5. Key			
3. Display		6. Appearance			
Sensitivity inspection:					
Location	Sensitivity				
Loc. I	970	950	850		
Loc. II	970	950	850		
Loc. III	970	950	850		
Loc. IV	970	950	850		
Loc. V	970	950	850		
Loc. VI	970	950	850		
Detected article	Ø20mm Steel ball	Ø30mm Steel ball	Ø40mm Steel ball		
Package inspected			Product inspected		
Verified by:			Inspected by:		

[Packing list]

Specification	()	8 sets of screws	()
Cable	()	Key	()
5mm Allen wrench	()		
Tested by:			Inspected by:

[“Green channel” after-sales service system]

- I. Instant response:** 24h hotline support; Reply within 4h; Service providing within 24 ~ 48h.
- II. One-month guarantee for replacement:** Any product with quality problem confirmed by the quality inspection department of our company can be replaced within 1 month after the purchase date.
- III. Two-year guarantee for maintenance:** The maintenance of the entire machine and main parts, provided by our company and domestic local joint guaranty agencies, as specified in the guarantee, is free within one year and two years respectively.
- IV. Lifetime service:** The joint guaranty agencies established by our company provides lifetime services regarding technical advice, technical training, product technology upgrading etc.
- V. Regular inspection:** A regular inspection service will be provided after the product is purchased in order to keep stable operation of the equipment.
- VI. Customization:** The product can be designed and produced separately according to the actual situation and the user’s requirement.

[Maintenance document]

- I.** This document shall be kept carefully for the sake of maintenance.
- II.** This document will be considered as invalid without the signature and seal of specified agencies.
- III.** Three Guarantees and Acknowledgment without detailed information will be considered as invalid. Please check the Three Guarantees and Acknowledgment for being provided with correct and detailed information. The Three Guarantees and Acknowledgment shall be submitted to the dealer for the sake of providing services.
- IV.** Reissuance of this document due to loss is not allowed.

Guarantee Card

Model		Serial No.	
Purchase date		Tel	
Contact		Fax	
Company name			
Address			

Maintenance Record

Maintenance date	Maintenance record	Maintained by

[Disclaimer]

- I.** This specification, though prepared based on correct and detailed information, does not mean that no missing or incorrect explanation of any part will occur.
- II.** The software and hardware of this product are subject to change without notice.
- III.** Our company reserves the final right of interpretation of this specification.